

Power Steering Pump — 4.0L

Special Tool(s)

 <p>ST1444-A</p>	<p>Installer Set, Teflon® Seal 211-D027 (D90P-3517-A) or equivalent</p>
---	---

Material

Item	Specification
<p>MERCON® V Automatic Transmission Fluid XT-5-QM (or XT-5-QMC) (US); CXT-5-LM12 (Canada)</p>	<p>MERCON® V</p>

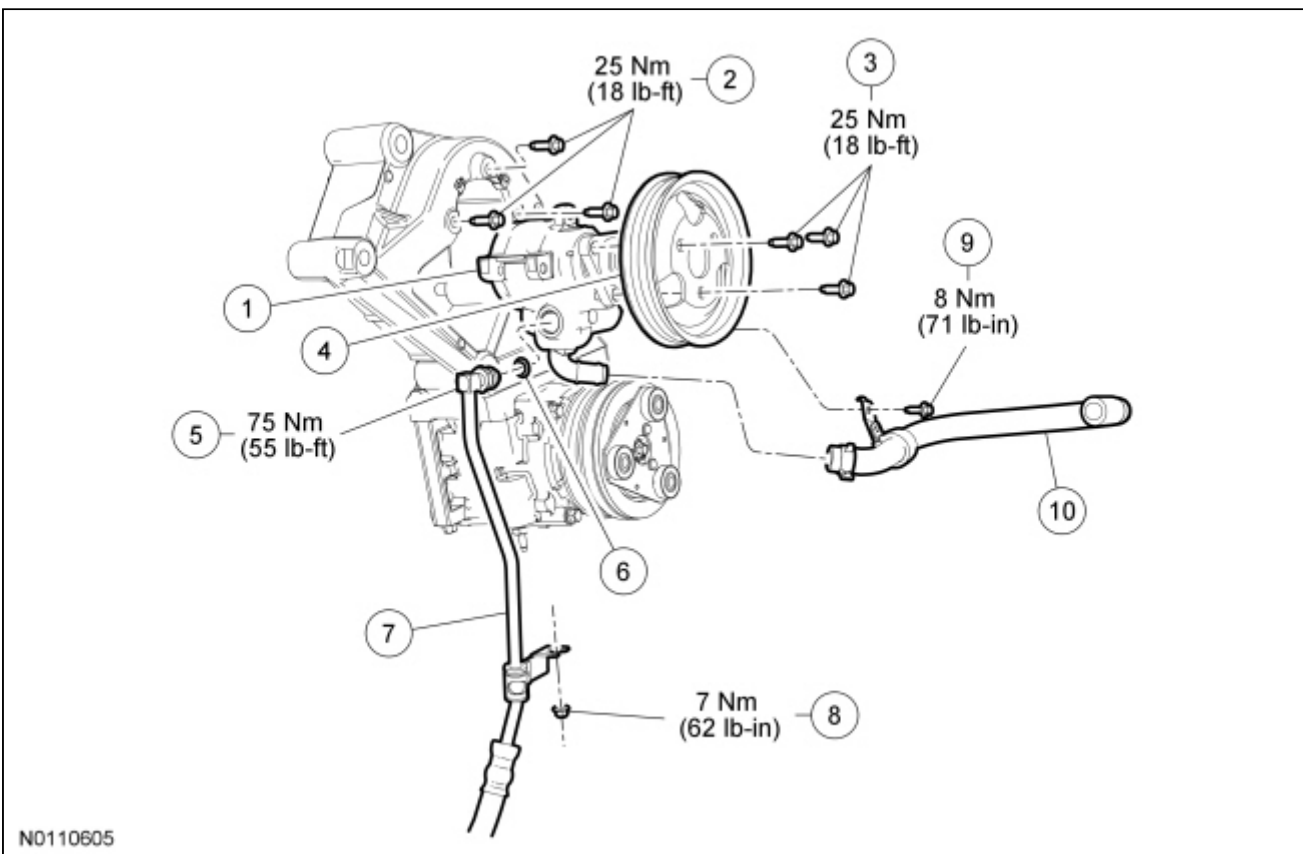

Item	Part Number	Description
1	3A674	Power steering pump
2	W700839	Power steering pump bolts (3 required)
3	N605784	Power steering pump pulley bolts (3 required)
4	3A733	Power steering pump pulley
5	—	Pressure line-to-pump fitting (part of 3A719)
6	388898	Teflon® seal

7	3A719	Power steering pressure line
8	W503924	Pressure line bracket-to-A/C compressor stud nut
9	W503934	Power steering pump supply hose bracket bolt
10	3691	Power steering pump supply hose

Removal and Installation

NOTICE: When repairing the power steering system, care should be taken to prevent the entry of foreign material or failure of the power steering components may result.

1. Remove the Air Cleaner (ACL) outlet pipe. For additional information, refer to [Section 303-12](#).
2. Using a suitable suction device, remove the power steering fluid from the fluid reservoir.
3. Loosen the 3 power steering pump pulley bolts.
4. Rotate the tensioner and remove the accessory drive belt from the power steering pump pulley.
5. Remove the 3 bolts and the power steering pump pulley.
 - To install, tighten to 25 Nm (18 lb-ft).
6. Release the clamp and disconnect the power steering pump supply hose from the power steering pump.
7. Remove the pressure line bracket-to-A/C compressor stud nut.
 - To install, tighten to 7 Nm (62 lb-in).
8. Remove the power steering pump supply hose bracket bolt.
 - To install, tighten to 8 Nm (71 lb-in).
9. **NOTE:** A new Teflon® seal must be installed.

Disconnect the pressure line-to-pump fitting from the power steering pump.

- Discard the Teflon® seal.
 - To install, tighten to 75 Nm (55 lb-ft).
10. Remove the 3 bolts and the power steering pump.
 - To install, tighten to 25 Nm (18 lb-ft).
 11. **NOTE:** For additional information on the accessory drive belt routing, refer to [Section 303-05](#).

To install, reverse the removal procedure.

12. **NOTE:** A new Teflon® seal must be installed.

Using the Teflon® Seal Installer Set, install a new Teflon® seal to the pressure line-to-pump fitting.

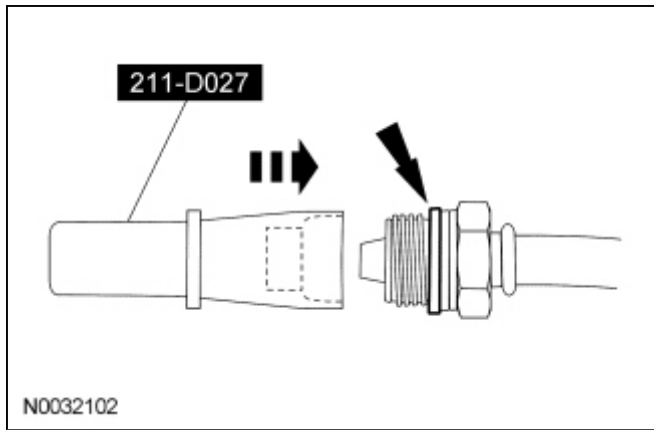

13. Fill the power steering system. For additional information, refer to [Section 211-00](#).
-